

Introduction to Encog

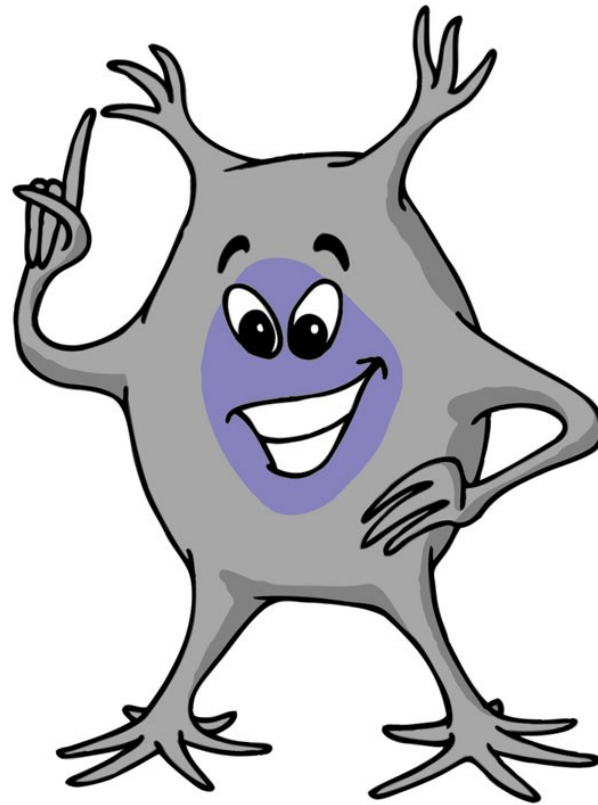

What is Encog

The Encog Artificial Intelligence Framework provides neural network, problem solving, and bot functionality to Java and .Net applications. Encog allows feedforward, recurrent, Hopfield, self organizing map and other types of neural networks to be expressed. Encog neural networks can be stored in XML files and can be graphically edited using the Encog Workbench. Encog is open source and released under the Lesser GNU Public License (LGPL).

<http://www.encog.org>

Jeff Heaton

- One of the lead Encog developers
- Software Developer for RGA
- <http://www.jeffheaton.com>
- jheaton@heatonresearch.com
- Twitter: <http://twitter.com/jeffheaton>

What are Neural Nets Used For?

- Problems with a very large search tree
- Data Mining
- Forecasting
- Providing Subjects for Sci-Fi Movies

What is a Neural Network?

- Accepts an array of doubles
- Outputs an array of doubles
- Made up of layers of similar neurons
- Weight matrixes between layers

Neural Network

[0.23, 0.45, -0.95, 0.44]

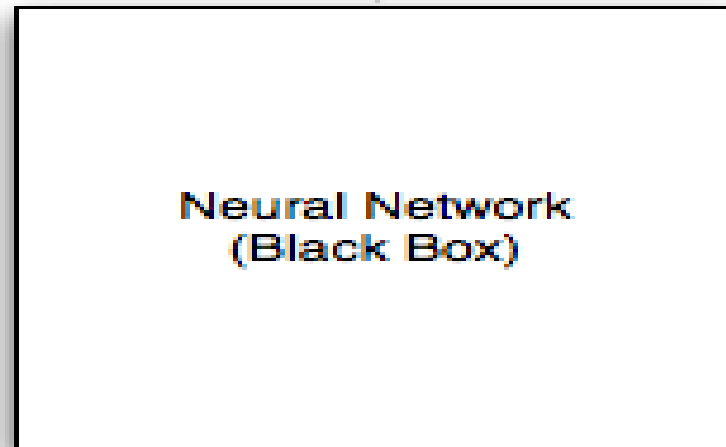

[-0.45, 0.33, 0.22]

Neural Network Input

- Input must be an array of doubles
- Can be normalized
- Many creative ways to map real data to doubles
-

Neural Network Output

- Output from the neural network is also an array of doubles
- May be normalized as well
- Output may be winner take all

Inside the Black Box

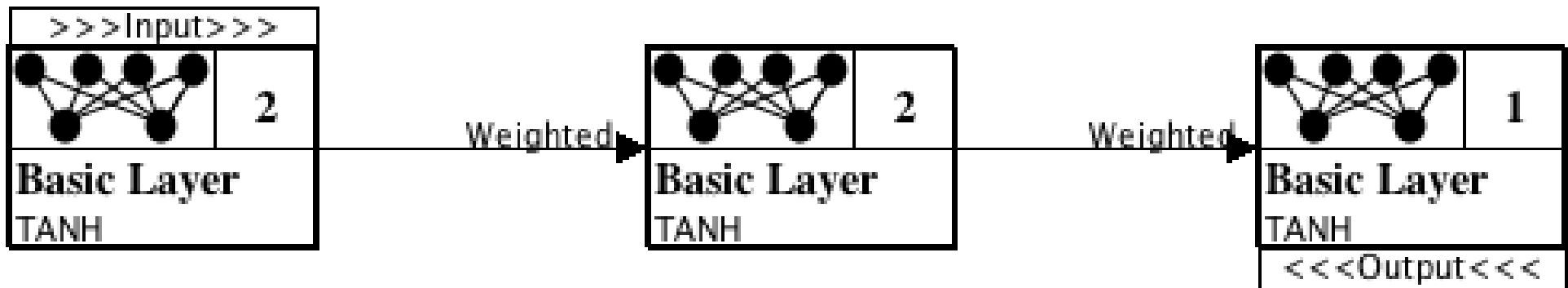

Multilayer

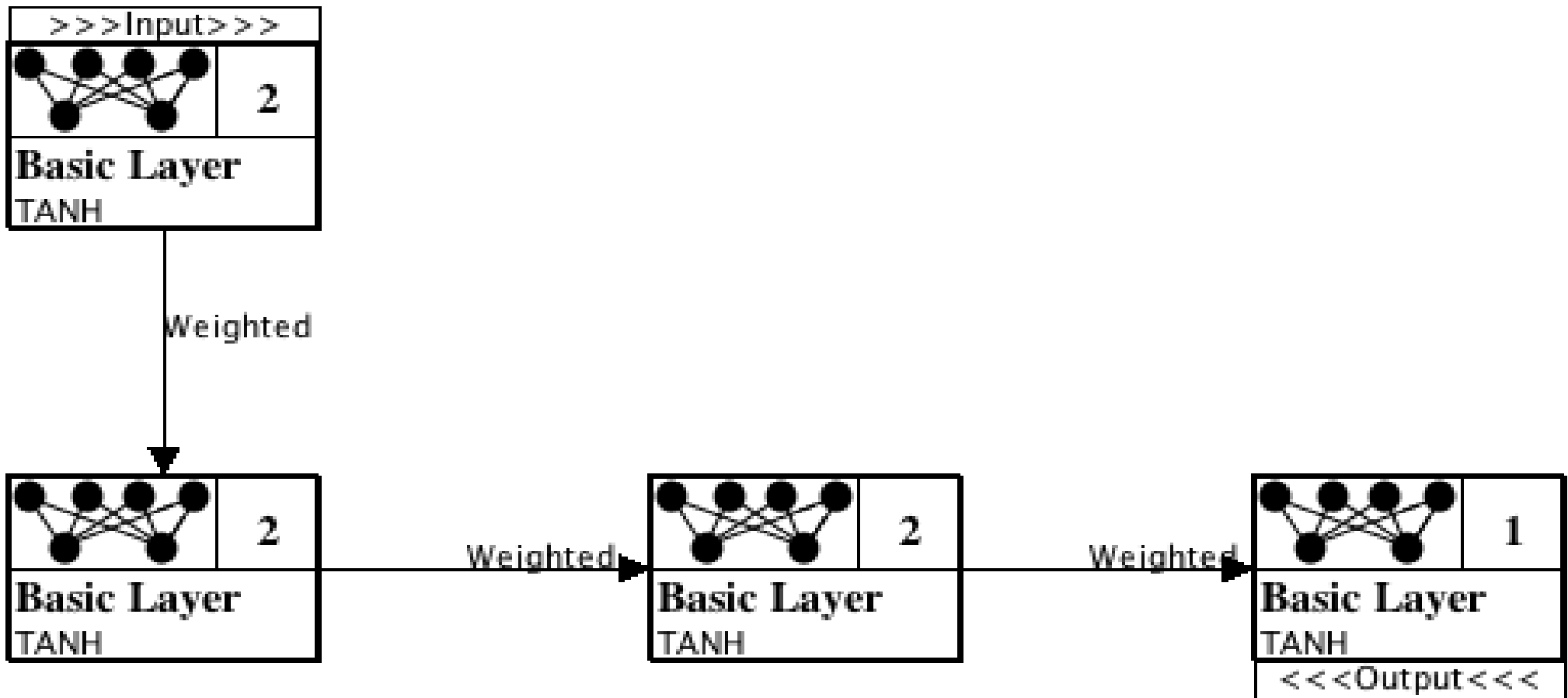

Context Networks

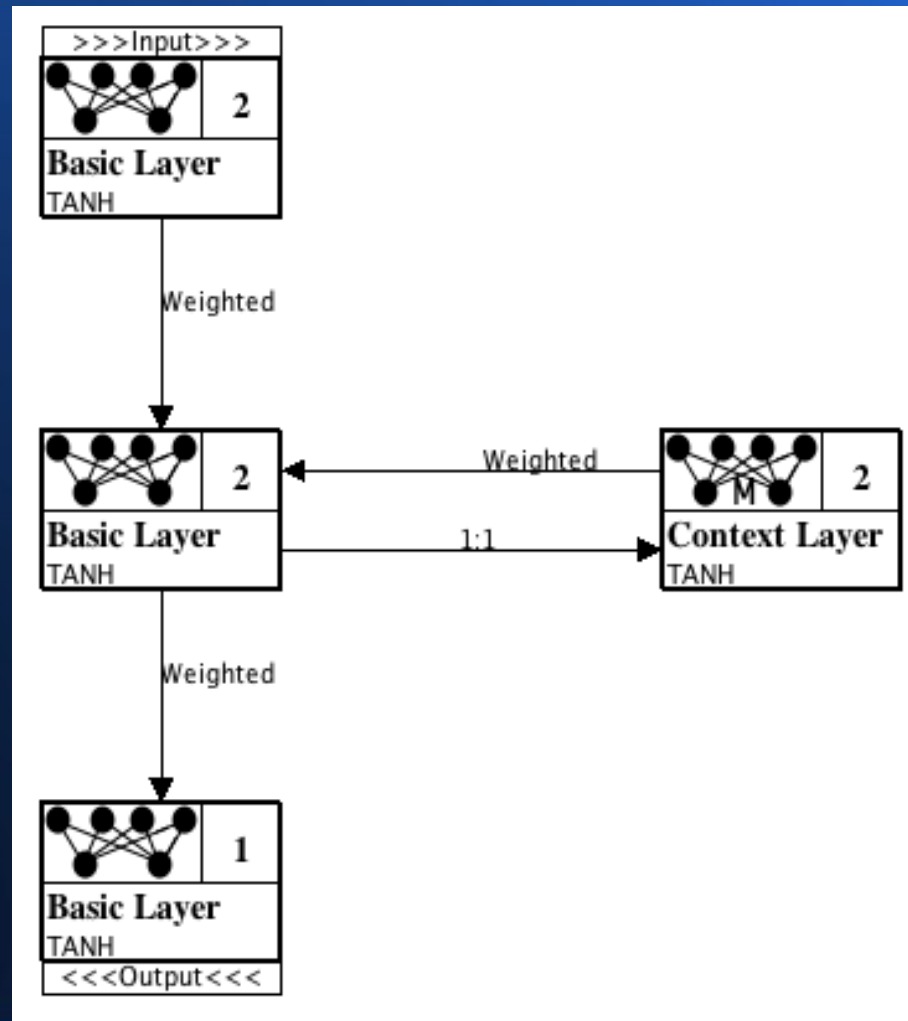

The XOR Function

Input-1	Input-2	Output-1
0	0	
0	1	
1	0	
1	1	

An XOR Neural Network

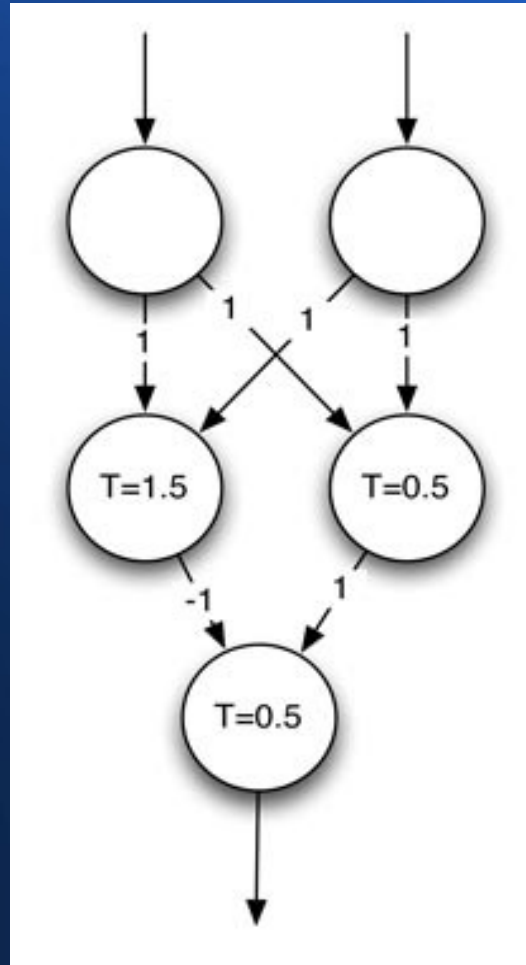

Automated Training

- Handcoding only works for small networks
- Larger networks can be trained automatically
- Many different ways to train a neural network

Training Supported by Encog

- Backpropagation
- Resilient Propagation
- Manhattan Update Rule
- Simulated Annealing
- Genetic Algorithms
- Competitive Learning

Constructing a Neural Network

```
BasicNetwork network
    = new BasicNetwork();
network.addLayer(new BasicLayer(2));
network.addLayer(new BasicLayer(3));
network.addLayer(new BasicLayer(1));
network.getStructure()
    .finalizeStructure();
network.reset();
```

Training Sets

```
public static double XOR_INPUT[][] =  
    { { 0.0, 0.0 }, { 1.0, 0.0 },  
      { 0.0, 1.0 }, { 1.0, 1.0 } };  
  
public static double XOR_IDEAL[][] =  
    { { 0.0 }, { 1.0 }, { 1.0 }, { 0.0 } };
```

Training the Network

```
final Train train = new
ResilientPropagation(network, trainingSet);

int epoch = 1;
do {
    train.iteration();
    System.out.println("Epoch #" + epoch + "
Error:" + train.getError());
    epoch++;
} while(train.getError() > 0.01);
```

Query the Neural Network

```
System.out.println(
    "Neural Network Results:");

for(NeuralDataPair pair: trainingSet ) {
    NeuralData output =
        network.compute(pair.getInput());
    System.out.println(
pair.getInput().getData(0) + "," +
pair.getInput().getData(1)
        + ", actual=" + output.getData(0) +
",ideal=" + pair.getIdeal().getData(0));
}
```

Optical Character Recognition

- OCR is a common use of neural networks
- Often uses a self-organizing map
- OCR Example
- 26 output neurons
- 5x7 grid of input neurons
- Show example...

Neural Network Prediction

- Create an input window
- Input window used to predict future direction
- Encog uses Yahoo Finance
- Show stock prediction example...

Encog Summary

- Neural Networks
- Bots & Spiders
- Natural Language Processing
- Encog 2.1 and Beyond
- <http://www.encog.org>